



Original Operating Instructions

For ErgoStrap Air 712-580 / 725-580 / 740-580

Serial No. _____

Declaration of conformity

EU declaration of conformity for the purposes of the EU machine directive 2006/42/EG

Firma ErgoPack Deutschland GmbH
Hanns-Martin-Schleyer-Str. 21
89415 Lauingen

We hereby declare that the devices "ErgoStrap Air 712-580 / Air 725-580 / Air 740-580", to which this declaration refers, complies with all the relevant and basic health and safety requirements because of their concept, type of construction and the model we have brought on to the market.

This declaration loses its validity if a change is made to the machine without our permission.

Respective

EU directives:

EU Machine directive (2006/42/EG)
EU Low voltage directive (2006/95/EG)
EU Guideline on electromagnetic compatibility
(2004/108/EG)

Applied standards

EN ISO 12100: 2011
EN ISO 13849-1:2007
EN 60204-1:2007 + A1:2009
EN 61000-6-2:2005
EN 55011: 2009 + A1:2010 (Marginal class B)
EN 415-8:2011

Lauingen, 15th January, 2014



Andreas Kimmerle
CEO

Validity of the operating conditions

ErgoStrap Air 712-580

Strapping unit with electrical drive, electronically controlled via joystick, with sealing head for strap widths of 9-13 mm and a maximum tension of 1200N, electronically adjustable for heights from 2,5- 57cm.

ErgoStrap Air 725-580

Strapping unit with electrical drive, electronically controlled via joystick, with sealing head for strap widths of 12-16 mm and a maximum tension of 2500N, electronically adjustable for heights from 2,5- 57cm.

ErgoStrap Air 740-580

Strapping unit with electrical drive, electronically controlled via joystick, with sealing head for strap widths of 16-19 mm and a maximum tension of 4000N, electronically adjustable for heights from 2,5- 57cm.

List of contents

1	Technical data	Page
	1.1 Strapping unit	5
	1.2 Sealing head	6
	1.3 Charger, battery, battery change trolley	7
2	General	8
	2.1 Notes on environmental protection	9
3	Safety regulations	10
	3.1 Safety regulations for operation of strapping unit	10
	3.2 Safety regulations for charger and battery	15
4	Description	16
	4.1 Design	16
	4.2 Control panel of strapping unit	17
	4.3 Control panel of sealing head	17
	4.4 Indications of the Dual charger	18
	4.5 Safety band switches	19
5	Installation	20
	5.1 Lifting and unloading of the machine	20
	5.2 Battery charger	21
	5.3 Charging the battery	21
	5.4 Fuses of the battery	23
6	Operation	24
	6.1 Setting of strap width at the sealing head	24
	6.2 Switching on the control unit	25
	6.3 Choosing the correct tension force/ range	26
	6.4 Setting the tension force at the sealing head	27
	6.5 Setting mode of operation of the sealing head	28
	6.6 Loading / changing the strap coil	29
	6.7 Setting pallet width	36
	6.8 Setting and saving of strapping height	41
	6.9 Strapping	42
	6.10 Tensioning and welding	49
	6.11 Sealing control	53
	6.12 Setting the welding time	54

7 Servicing and repair	55
7.1 Cleaning the guiding ChainLance	55
7.2 Cleaning/replacing tension wheel of sealing head	56
7.3 Cleaning/replacing tooth plate of sealing head	57
7.4 Replacing knife of the sealing head	58
7.5 Cleaning ultrasonic sensors	58
8 Save moving and parking	59
9 Spare part lists	59

1. Technical data

1.1 Strapping unit

Weight (ready for use)

- incl. battery

- without strap

- without lifting device 280 kg

Dimensions

	without control panel (removable)	including control panel
Length:	1340 mm	1360 mm
Width:	1120 mm	1240 mm
Height min (height adjustment at lowest point):	1600 mm	
Height max (height adjustment at highest point):	1930 mm	

Maximum speeds of chain:

Moving out horizontally: 40 m/min

Moving out vertically: 60 m/min

Max. chain thrust:

310 N

Measured A-assessed

Noise emission level

(EN ISO 11202)

L_{pa} 79 dB (A)

1.2 Sealing Head

Weight (incl. spiral cable)	3,9 – 4,2 kg
Dimensions	Length 330 mm Width 135 mm Height 130 mm
Tension	
Air 712-580	150 – 1200 N
Air 725-580	400 – 2500 N
Air 740-580	400 – 4000 N
Tensioning speed	220 mm/S (Air 712-580) 220 mm/S (Air 725-580) 175 mm/S (Air 740-580)
Sealing	Friction welding
Measured A-graded noise emission level (EN ISO 11202)	
Air 712-580	L_{pa} 77 dB (A)
Air 725-580	L_{pa} 79 dB (A)
Air 740-580	L_{pa} 79 dB (A)
Hand arm vibrations (EN ISO 8662-1)	$a_{h,w}$ 2,2 ms ⁻²
Plastic strap Strap materials	Polypropylene (PP) Polyester (PET)

Strap width

Air 712-580, adjustable to 9 – 10 mm
11 – 13 mm

Air 725-580, adjustable to 12 – 13 mm
15 – 16 mm
9 – 11mm (optional)

Air 740-580, adjustable to 15 – 16 mm
18 – 19 mm

Strap thickness

Air 712-580 0,35 – 0,85 mm
Air 725-580 0,50 – 1,00 mm
Air 740-580 0,80 – 1,30 mm

1.3 Charger, battery, battery change trolley

Charger 3-step-lead-charger
Prim.: 100-240 VAC 50/60 Hz max. 5,0 A
Sec.: 2 x 12 V DC/5A
Total max. power 2 x 73,5 W

Battery 24V AGM battery
Weight: 39,5 kg
Length: 580 mm
Width: 225 mm
Height: 220 mm

Charging time: approx. 8 hours

Temperature range: 5 °C – 40 °C

Number of strappings: 150 to 500 per charge, depending on size of pallet, tension, welding time, frequency of height adjustments and battery temperature.

Life span: approx. 500 charges

Battery change trolley

Weight: 13 kg Width: 550 mm
Length: 720 mm Height: 1035 mm

2. General

These operating instructions shall help get to know the machine and to work with it according to its intended use. The operating instructions contain important notes on how to use the machine safely, properly and economically.

Adhering to the notes helps to avoid dangers, repairs and down times and also increases the reliability and life span of the machine.

The operating instructions must be available at the place where the machine is used. It has to be read, understood and used by everybody working with the machine. These works include operation, maintenance and repair.

In addition to the operating instructions and the regulations in the country and place of use related to the prevention of accidents, the recognized special rules for working safety and according to proper and professional standards also have to be respected.



Be careful!

This sign indicates danger to life and health.



Attention!

This sign indicates dangers can cause damage to property.



Note!

This sign indicates general warnings in order to avoid any interruption of operation.

2.1 Notes on environmental protection

Physical or chemical materials which could be injurious to health have not been used for manufacturing the machine.

The valid, legal regulations have to be taken into consideration during disposal. The electrical components have to be dismantled first, so that the mechanical, electromechanical and electronic components can be disposed separately.

Specialist dealers offer disposal according to proper environmental protection.

- Do not open the battery
- Do not throw the used battery into the domestic waste, fire or water.

3. Safety regulations

3.1 Safety regulations for operating the strapping unit



Inform yourself!

The operating instructions have to be read carefully and understood before using the machine. The machine may only be serviced and maintained by trained personnel.



Wear protective helmet!

Wear protective helmet when strapping pallets exceeding a height of 1,20 m.

The obligation to wear a helmet can be avoided if the operator was taught about the risk of injury by the plastic chain falling down. This instruction has to be recorded in written.



Protect yourself!

Wear eye and hand protection (cut proof gloves) and also safety boots when working with the equipment.



Energy source!

Before servicing and maintenance work:
Switch the machine off (Press “O” and remove the battery plug)



Be careful:

Be aware of hands or other parts of the body that may get caught between the strap and the goods to be strapped.



Be careful: The strap can rip!

The strap can rip when being tensioned!
Do not stand in the line of the strap.



Do not use any water!

Water or steam must not be used for cleaning the machine.



Caution when cutting tensioned straps!

Hold the upper part firmly when cutting the strap and do not stand in line with the strap.

Attention:

The lower part of the strap will snap!



Only use original ErgoStrap spare parts!

The use of other non-ErgoStrap parts invalidates guarantees and liability.



Attention : Risk of stumbling!

When the machine gets parked, the ChainLance must be completely retracted.

It must not protrude from the machine.

Furthermore, it must be assured that any potential strap waste or strap pieces are removed from the floor immediately.



Attention: Risk of squeezing!

There is a risk of squeezing in the entire surroundings of the ChainLance, but especially between the metal chain pieces of the supporting ChainLance; also in the area of the reversing sledge, the tensioning wheel, the guiding wheel and between the lifting unit and the chassis.



Attention: Laser beam!

Direct eye contact with the laser beam or reflecting radiation may result in permanent eye injuries. Never look direct into the laser.

Laser category 2M

DIN EN 60825-1:2007

The operator must make sure before each strapping operation that no persons are in or entering the area of applications (especially where ChainLance operates).

Keep clear the area on the opposite side of the pallet where the operator only has a restricted view.

When the ChainLance on the other side of the pallet moves upwards, its own weight causes it to fall across the pallet in the direction towards the operator.

In case of inattention, the ChainLance might fall on the operator's head and cause injuries. Be careful and concentrated to catch the ChainLance as it falls across the pallet.

If the tensioning process cannot be stopped in any other way, it can be interrupted at any time by pulling the rocker lever at the tension unit or by pushing the emergency stop.

Pallets can only be strapped on even, dry and horizontal surfaces.

When changing the strap, the strap roll must be transported and placed by two persons if the weight of the roll exceeds 20 kg.

When changing the battery, it has to be lifted by 2 persons. It can be changed by only one person if the battery change trolley (available as accessory) is used.

The machine is not designed to be used in explosion proof areas (ex-areas).

Before using the machine for the first time, visual inspection must be done to check if there are any exterior damages.

Risk of crushing exists in the whole area of the chain, especially between the metal chain links of the supporting chain as well as between the lifting unit and the chassis.

The machine may not be used if any parts, especially covers, are dismantled. This applies also to all other parts - irrespective if they seem to be irrelevant for safety and/or minor important for functioning of and working with the machine.



Fig. 1a



Fig. 1b

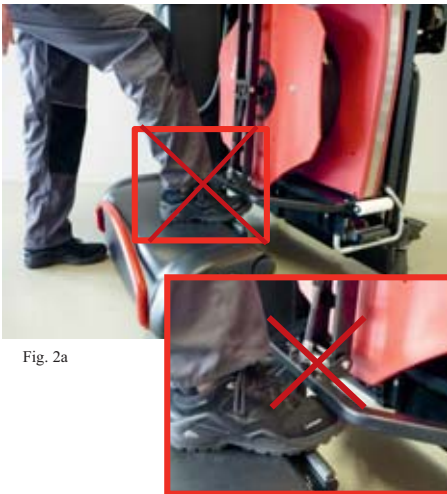

Fig. 2a



Fig. 2b

Intended use

This machine is designed for strapping pallets and was developed and constructed for safe use during this strapping operation.

The machine is designed only for strapping with plastic straps (polypropylene and polyester). Strapping with metal strap is not possible with this machine.

The machine is not designed for the strapping of unpacked food.

The pre-set tension force must correspond to the goods to be strapped (see 6.3). Constructing the machine there was not considered any risk due to damaging of dangerous products or their package.

The machine is not designed for lifting loads or/and persons.

3.2 Safety regulations for charger and battery



- Check the plug and the cable before each use and have them replaced by a specialist if they are damaged
- Do not use any batteries of other manufacturers, use original spare parts only.
- Keep the connection plug to the battery away from non-related objects and dirt.
- Protect the charger from moisture; operate it in dry rooms only.
- Do not open the battery and protect it from shock, heat and fire.
Danger of explosion!
- Store batteries in a dry frost-proof place. The ambient temperature must not exceed 50°C and must not fall below -5°C.
- Damaged batteries may not be re-used.

4. Description

4.1 Design



- Lifting column
- Safety strap cutter
- Circular disk for strap
- Supporting ChainLance with guiding ChainLance inside

Fig. 3

Compartment for battery with chassis protection
Lifting device



Fig. 5

Laser Guiding wheel



Fig.4

- Sealing head
- Control panel with joystick and colour display
- Sliding window with safety switch
- Triplex Tool-Lift
- Guide rollers with parking brake and overrun protection

4.2 Control panel of strapping unit

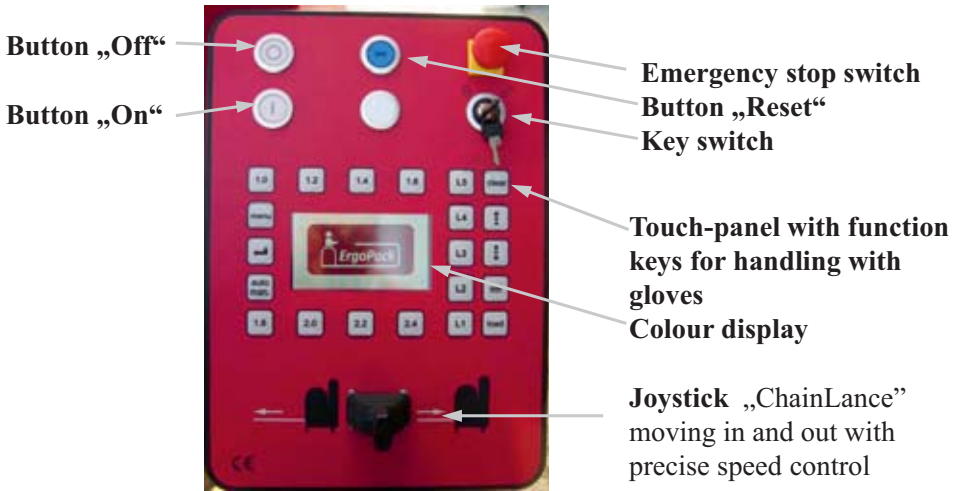
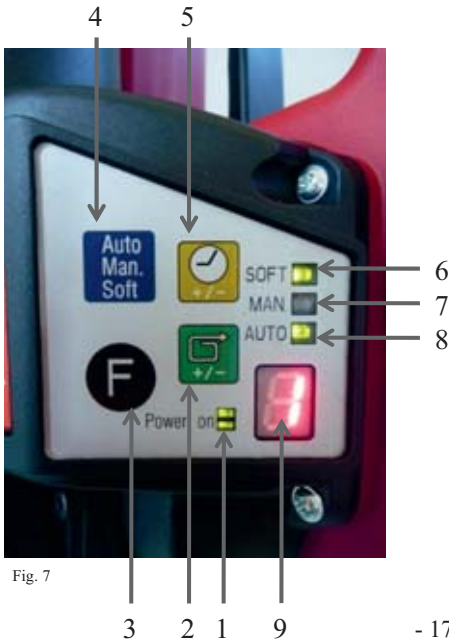

Fig. 6

4.3 Control panel of sealing head



- 1 LED indicator „Power on“
- 2 Button „Tension“
- 3 Button „Function“
- 4 Button „Mode of operation“
- 5 Button „Welding time“
- 6 LED indicator „Soft tension“
- 7 LED indicator „Manual strapping“
(continuous green light)
- 8 LED indicator „Automatic strapping“
(continuous green light)
- 9 Digital display for:
 - tension (1–9)
 - welding time (1–7)
 - cooling time (count down 3,2,1)
 - fault indication

Fig. 7

4.4 Indications of the Dual-Charger

Two 12V-batteries are plugged inside the red battery housing. The batteries are charged separately by the Dual charger.

There is a separate LED on the Dual battery charger indicating the charge of each battery.

LED continuous orange = quick charge

LED flashing orange = battery is charged at 80% , current charging flow is reduced until battery will be charged at 100%.

LED continuous green = battery fully charged, charger switches to conservation charge

LED flashing green = no battery connected, charger ready for use

Note:

The battery pack only is fully charged, if **both** LED indication lights are continuously green (not flashing!)

If only one LED is continuously green and the second LED is not green even if the first LED has been continuously green for already several hours, either the corresponding charging circuit inside the charger or one of the two fuses for the batteries' charging circuit are defective. In this case please see point 5.4 „Fuses of the batteries“ on page 23.



Fig. 8

4.5 Safety band switches

To avoid injuries caused by crushed extremities during height adjusting, the crushing edges are protected from grabbing inside by covers or secured by safety band switches.



Attention!

The machine may not be used if any parts, especially covers, are dismantled. This applies also to all other parts, independent if the operator considers them as not safety relevant and/or unimportant for the function and operation of the machine.



Fig. 9



Fig. 10

5. Installation

5.1 Lifting and unloading of the machine

Lift the machine from the truck or pallet by the lifting device using a crane or forklift as shown.

Place the machine on a flat and preferably even ground and remove the lifting device by taking out the lower locking pin.

Make sure the brakes of both guide rollers are blocked (pedals are in upright position):



Fig. 11a



Fig. 11b



Fig. 12a



Fig. 12b



lock guide rollers

Fig. 13a



unlock guide rollers

Fig. 13b



Attention!

Only the lifting device delivered with the machine may be used for lifting the machine. Any other lifting method means danger for man and machine. For using the lifting device, the pre-set strapping height must not exceed 10 cm (see 6.8). The lifting device has to be removed prior to any machine operation.

5.2 Battery Charger

The main voltage must comply with the details on the type plate.

The charger is only suitable for charging the provided 24 V lead battery.

The battery may be charged at any time, independent of its state of charge.

There is no memory effect.

5.3 Charging the Battery

- 1) Connect the charger to the main voltage
- 2) Open the battery cover (1) (Fig. 14a).
- 3) Turn the red ring (3) of the plug (4) on the battery (2) to the left (Fig. 14b)
- 4) Disconnect the plug (4) from the battery (2), (Fig 14b)



Note!

Before using the machine for the first time, a visual inspection for exterior damage has to be done.



Attention!

Charge the battery only with the ErgoStrap Dual 3-step charger through the blue socket. Always charge the battery completely, until both control lights are continuously green. Lifting of the charger only by two persons or by the ErgoStrap battery-change trolley. (Fig. 15, available as accessory)



Fig. 14a

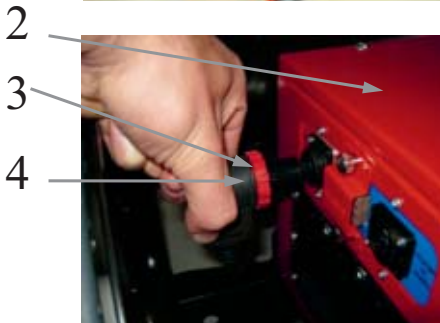

Fig. 14b



Fig. 15

- 5.) Put the blue plug (5) of the charger into the blue charging socket of the battery pack as shown in Fig. 16 by holding it 45° turned to the lower left corner. Then turn the plug clockwise to a horizontal position until it is locked.



- 6.) To remove the blue charging plug after charging is completed, please proceed as follows:
- a) pull the silver locking bar (6) backwards
 - b) turn the plug counter clockwise by 45°
 - c) remove the plug



Important!

The battery can be charged inside the machine, but you also can take it out. Charging the battery while operating the machine is not possible.

The charging time is approx. 8 hours. The battery is only fully charged if both LEDs of the charger are continuously green!

The maximum charge flows if the battery temperature is between 5 – 40°C. Avoid battery temperatures below 0°C when charging.

The longest life span will be achieved, if the battery is charged daily and not operated until the control unit switches off. Batteries not being used for a longer time (e.g. weekend) should always stay connected to the charger. The charger is automatically switching to conservation charge when the battery is full. Any overcharging is impossible.

5.4 Fuses of the battery

The battery has three circuits. Each circuit is protected by a separate fuse. The fuses are placed behind the red cover marked „FUSES“. Unscrew the two screws to remove the cover.

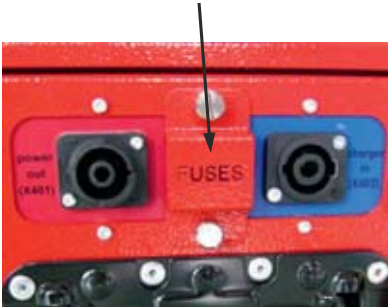

Fig. 19



Fig. 20

Circuit 1:

24V- output to strapping machine

Circuit 2+3:

2 x12V- input from charger (both circuits operated via the blue plug)

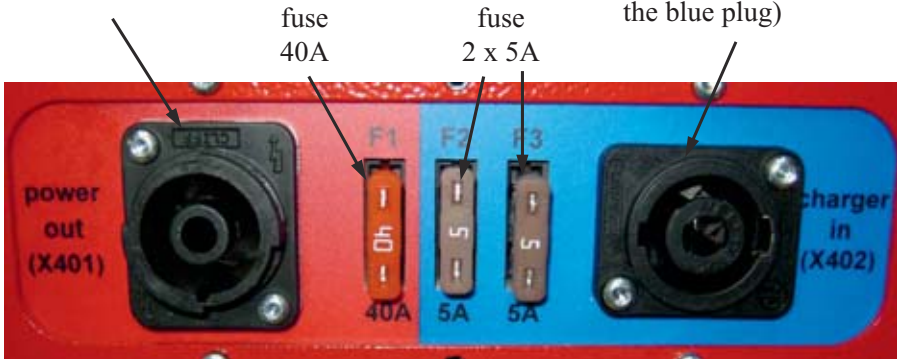

Fig. 21



Important!

Only circuit 1 is necessary for the operation of the machine. For charging the battery the circuits 2-3 are needed.

In case there is no possibility to start operation with the control panel in spite of full battery, either the key switch is turned to position „off“ (to the left) or the fuse 40 A of circuit 1 of the battery is not working. All three fuses are standard automotive fuses.

6. Operation

6.1 Setting strap width at the sealing head

The sealing head can be used with different strap widths:

ErgoStrap Air 712-580: 9 – 10 mm or 11-13 mm

ErgoStrap Air 725-580: 12 – 13 mm or 15 – 16 mm
9 – 11 mm (optional)

ErgoStrap Air 740-580: 15 – 16 mm or 18 – 19 mm

The setting of the strap width is explained using the example of model 725-580. The setting of the strap width with models 712-580 from 9 – 10 mm to 11 – 13 mm and 740-580 from 15 – 16 mm to 18 – 19 mm works accordingly.

a) Change strap width from 12-13mm to 15-16mm

- Switch off the machine “O”
- Release sunk screw (22/2) and remove strap stop 13mm (22/1)
- Lift the rocker lever towards the handle,
- release sunk screw (22/4) and remove strap guide 13 mm (22/3).
- Remove three cylindrical screws (23/2)
- Lift the rocker lever towards the handle, remove cylinder screw (23/4) and rear strap stop block 13 mm (23/3)
- Remove cover (23/1).
- Remove oval-head screw (23/7) and remove rear strap guide 13 mm (23/6) from lever
- Install cover (23/1)
- Mount rear strap stop block 16 mm (23/5)

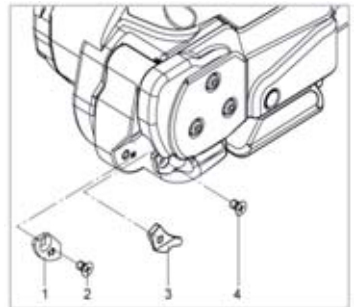

Fig. 22

b) Change strap width from 15-16mm to 12-13 mm

- Mount 13mm strap stop (22/1) and secure sunk screw (22/2) with Loctite 222
- Mount 13mm strap guide (22/3) and secure sunk screw (22/4) with Loctite 222
- Remove rear strap stop block 16 mm (23/5)
- Remove three cylinder screws (23/2) and cover (23/1)
- Mount rear strap guide 13mm (23/6)
- Install cover (23/1)
- Mount rear strap stop 13mm (23/3)

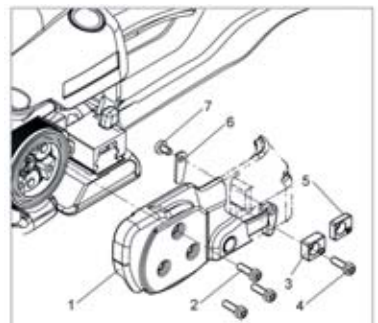

Fig. 23

6.2 Switch-on the control unit

1st step

- Charge battery as described in 5.3
- Connect the plug of the power cable (3) into the red-rimmed socket (4) of the battery and lock it by turning the red ring (2) clockwise (right).
- Make sure that the emergency stop (9) is not pressed (unlock by turning clockwise/right).
- Press button „I“ (11)
- Once the Logo „ErgoStrap“ has disappeared, follow the instructions on the display.



Fig. 24

3 2 4



Fig.25

8

2nd step

The control unit is in the teaching mode.

Now move the joystick (8) completely to the „move out“ or in the „move in“ direction and keep it pushed until the display shows „main menu“. The control unit is now ready for operation.

The 7 segment indicator lights up on the display of the sealing head. Also the sealing head is now ready for operation.

6.3 Setting the strap tension range at the sealing head

Two tension ranges can be set at the sealing head:

- STANDARD** = 400-1200 N (712-580); 900-2500 N (725-580); 1200-4000 N (740-580),
Standard, PET straps
- SOFT** = 150-750 N (712-580); 400 - 1500 N (725-580); 400-1600 N (740-580),
Soft tension* PP straps

SOFT-tension mode:

- Press function button (26/1)
- Press button „mode of operation“ (26/2) several times until the green SOFT LED (26/3) lights up together with the desired mode of operation .



Important!

By applying the SOFT tension mode, the tension wheel is accelerating slower and an excessive pollution when using PP strap will therefore be avoided.

When working with PP strap always use the SOFT tension mode!

ErgoStrap Air 712-580

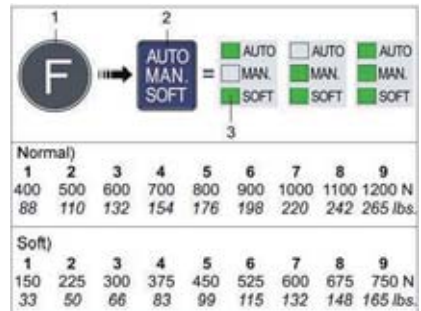

Fig. 26a

ErgoStrap Air 725-580

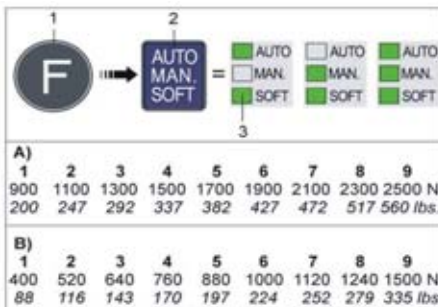

Fig. 26b

ErgoStrap Air 740-580

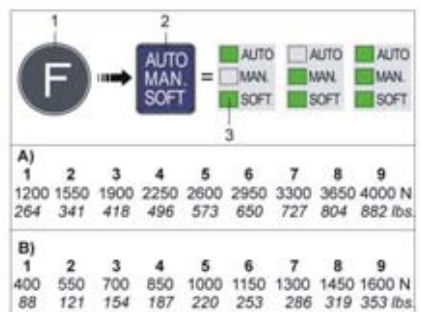
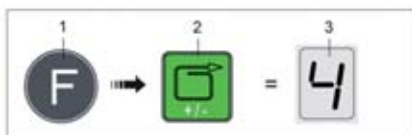

Fig. 26c

6.4 Setting strap tension at the sealing head

- Press the „Function“ button (27a/1)
- Press the „Strap tension“ button (27a/2) several times until the flashing digital display (28/3) shows the required strap tension (wait 2 seconds until the new setting has been saved).



1 = min. strap tension according to table 26a – 26c
9 = max. strap tension according to table 26a – 26c

Fig. 27a



The adjusted tension force must correspond to the packaged goods to be strapped. Constructing the machine, there was not considered any risk due to damaging of dangerous products or their package.

6.5 Setting mode of operation

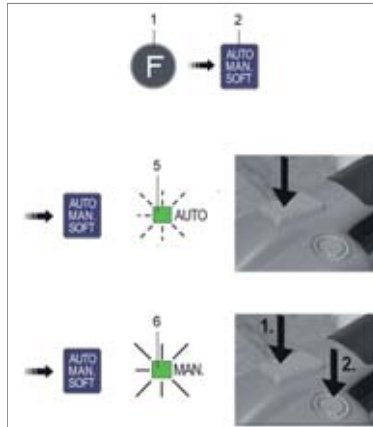

Fig. 27b

- Press „Function“ button (27b/1).
The digital display shows „F“ (Function). The present mode of operation is shown.
- Then press the „Mode of operation“ button (27b/2) until the desired mode of operation is shown.

Auto strapping:

Strapping is performed by pressing the tension button. When the strap tension is reached, welding and cutting is performed automatically.

- If the „AUTO“ LED indicator light (27b/5) is continuously green, the operation mode „Automatic“ is selected.

Manual strapping:

Strapping is performed by first pressing the tension button. When the adjusted tension is reached, press the welding button.

- When the „MAN“ LED indicator light (27b/6) is continuously green, the operation mode „Manual“ is selected.

6.6 Putting on/changing the strap coil

For putting on/changing the strap coil use the “Load Mode”. The control unit has to be in the main menu and the supporting ChainLance has to be completely inside the machine. See also point 6.2 „Switch-on control unit“.



Attention!

Make sure the lifting device is removed as described under point 5.1. The electronic height adjustment can only be performed without the lifting device. Otherwise it can lead to damages and injuries.

Start the menu „Load“ by pressing the button „load“.

You see the following screen at the display:

Load-Mode

8 steps to change strap roll

‘load’- button = next step
‘clear’- button= back to Main Menu



Important!

Each next step will be shown by pressing the “load” button.

By pressing the „clear“ button, the “load” mode can be interrupted at anytime and you can go back to the main menu.

Follow now all 8 steps.

Step 1

Keep ‘load’-button pressed until upper switch off position is reached

‘load’- button = next step
‘clear’- button = back to Main Menu

Upper switch-off position reached

Step 2

Put on a new strap roll

'load'- button = next step

'clear'- button= back to Main Menu



Fig. 28



Fig. 29



Fig. 30

Step 3

Open sliding window and push the strap through the yellow slot.

'load'- button = next step

'clear'- button= back to Main Menu



Fig. 31



Fig. 32

Step 4

Slide the strap through the clamp lock located in the red chain link and close the sliding window again.

'load'- button = next step

'clear'- button= back to Main Menu



Fig. 33



Fig. 34



Fig. 35

Step 5

Keep 'load' button pressed until step 6 will be displayed.

(The unit goes fully down to reset height measurement, thereafter up again by approx. 10 cm)

'load' - button = next step

'clear' - button = back to Main Menu

Step 6

Keep 'load' button pressed until chain feed stops

'load' - button = next step

'clear' - button = back to Main Menu



Fig. 36

Step 7

Take the strap out of the clamp lock and keep the strap tensioned in your left hand. With your right hand simultaneously press 'load' button until chain feed stops.

'load' - button = next step

'clear' - button = back to Main Menu



Fig. 37



Fig. 38

Step 8

Feed strap through the eccentric lock located at the top of the ChainLance and keep the strap slightly tensioned with your left hand. Simultaneously press 'load' button until ChainLance is fully retracted and load-Mode is finished.



Fig. 39



Fig. 40



Fig. 41



Important!

Make sure the strap remains tensioned continuously while the ChainLance is moving back, in order to avoid the strap being pushed back into the machine by the ChainLance.

As shown below, form a loop and place the overlapping strap through the slot for strap fixture



Fig. 42

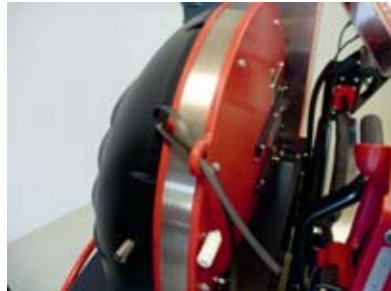

Fig. 43

Your ErgoStrap „Air“ is now almost ready for strapping – only adjust pallet width and strapping height and you are ready to go!

The next pages will show you how easily and quickly this is done.

6.7 Setting pallet width

Your ErgoStrap Air disposes of the world's first Double-ChainLance system with automatic pallet width detection.

How is it working:

The white chain (guiding ChainLance) threads the strap through the pallet and back up again on the opposite side of the pallet, back into the hand of the operator.

The guiding ChainLance is kept at the adjusted strapping height on its horizontal way through and underneath the pallet by the black aluminium chain (supporting ChainLance).

As soon as the reversing unit at the front end of the supporting ChainLance has passed completely underneath the pallet, the supporting ChainLance will be locked by a magnet locking bar.

As the guiding ChainLance continues to move out, the reversing unit turns to a vertical position and the ChainLance finally brings the strap up at the back side of the pallet and over it back to the operator.

How far the supporting ChainLance moves out until it is locked by the magnet locking bar (= width of pallet) can be set manually. The width can also automatically be detected by the ultrasonic sensors located next to the reversing unit.



Fig. 44



Fig. 45

- Magnet locking bar
- Guiding ChainLance
- Reversing unit
- Supporting ChainLance
- Ultrasonic sensors
- Safety band switch

Press the button „auto/man.“ to switch between manual setting and automatic detection of pallet width. The selection is shown on the display in the main menu. The manual mode shows the set pallet width (e.g. 1,6 m), the automatic mode shows „auto detect“.

Important: If the pallet width is 2,0 m or wider, a support point for the supporting ChainLance between 1,0 m and 1,8 m is necessary (best: wooden for low wear out, like pallet board).

Display
 “auto detect“ or
 pallet width “1,0 m-2,4 m“

Button
 auto/man.

Buttons
 1.0 m – 2.4 m

Main menu	
Pallet width:	auto detect
L5:	56,0 cm
L4:	22,5 cm
L3:	51,1 cm
L2:	1,5 cm
L1:	0,0 cm
Present height:	10,0 cm



Fig. 46



Important information for the function „automatic detection of pallet widths“

The two ultrasonic sensors at the front end of the supporting ChainLance are sending out cone-shaped ultrasonics to the top. The cone of radiation is inclined to the front by 7° and has a height of approx. 1,20 m.

The sensors will recognize if the Double-ChainLance is underneath the pallet. The ChainLance is moving out continuously, as long as the operator is pushing the joystick in the „Move out“ direction and the sensors register an object situated within the reflecting cone. (see picture page 39).

As long as the sensors register an object within the reflecting cone, the magnet locking bar cannot lock the support ChainLance. This would lead to the reversing unit folding up the below the pallet which could lead to damages at the reversing unit and the support ChainLance.

As soon as the reversing unit and the sensors located at its side have passed the pallet underneath and appear at the opposite side, the magnet locking bar will get the signal to lock the support ChainLance if there is no object left in the reflection cone. The magnet locking bar will not lock the supporting ChainLance before it moved out 0,80 m to make sure the reversing unit is not folding up between the machine and the pallet already.

This means

- **in „Automatic width detection“-mode:**
The supporting ChainLance is locked by the magnet locking bar to fold up the reversing unit.
- **in „Manual width setting“-mode:**
The support ChainLance is moving out until the manually set pallet width, which is shown in the main menu, is reached. Thereafter, the magnet locking bar locks the supporting ChainLance and the reversing unit folds up.

Also if used in “manual width setting-mode” the ultrasonic sensors check if the reversing unit completely passed the pallet. Only after they give the signal that the pallet is cleared, the lock of the magnet locking bar will be released.

Attention!



If there is an object or a person behind the pallet recognized by the reflecting cone, the magnet locking bar will not lock the support ChainLance. As a result, the support ChainLance continues to move out, despite the fact that the reversing unit already passed the pallet completely.

The ultrasonic sensors cannot differ between a pallet and an object/person!

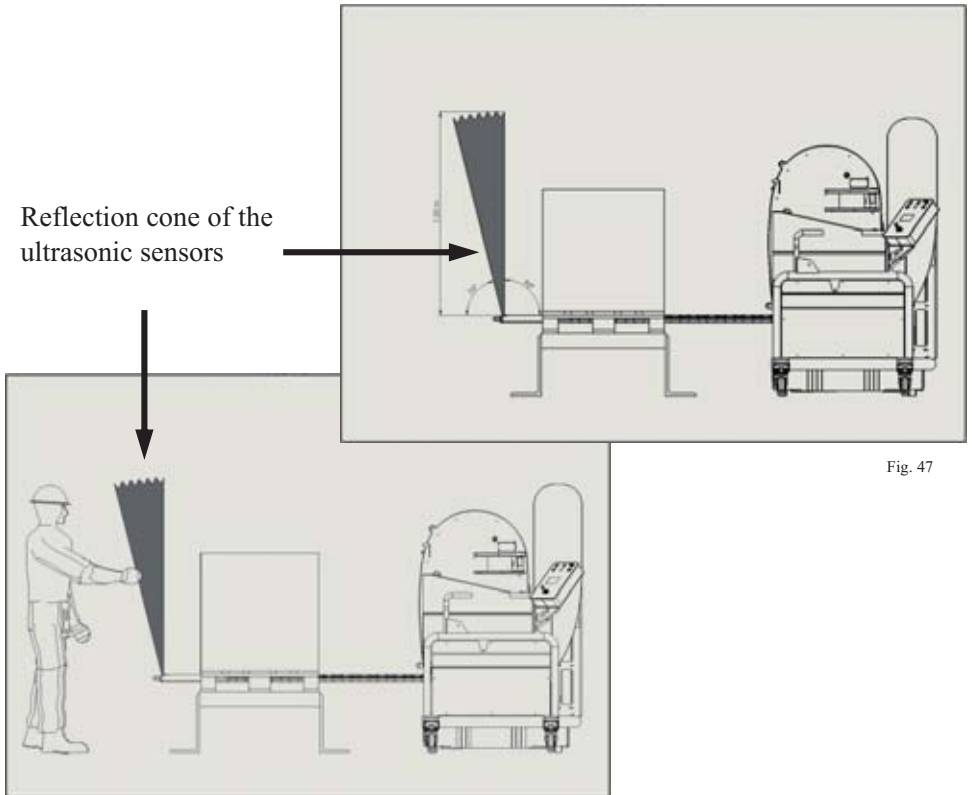

Fig. 47

Fig. 48

As soon as the safety band at the front end of the supporting ChainLance is touching an obstacle, the machine stops immediately. To start it again the “reset” button has to be pressed. The corresponding information will be shown on the display.

WRONG strap position

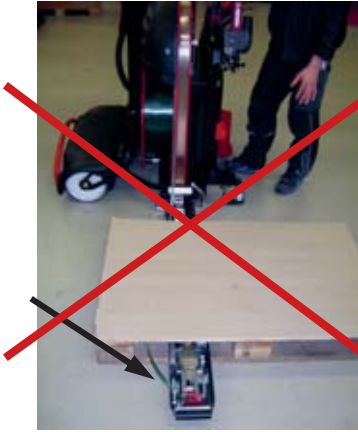

Fig. 49



Fig. 50

Strap inside
the reflecting
cone of the
ultrasonic
sensors

The strap is within the area of the reflecting cone of the ultrasonic sensors and realized as an obstacle. Therefore, the magnet locking bar cannot lock the supporting ChainLance despite the fact that the reversing unit already passed the pallet.

CORRECT strap position



Fig. 51

Hold the strap
to the left

Strap outside
the reflecting
cone of the
ultrasonic
sensors

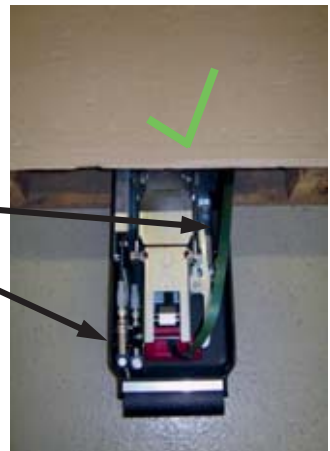

Fig. 52

While the Double ChainLance is moving out, the operator holds the strap to the left and lets it slide through his hand keeping it slightly tensioned. Once the Double ChainLance has moved out by about 0,5 m, you can let go of the strap. There is no more risk for it to get into the reflecting cone of the ultrasonic sensors.

6.8 Setting and saving of strapping height

Press the “set” button to open the mode for setting and saving different heights. The currently set height is shown in the display.

Measure the height the support ChainLance has to move out (bottom end) and add about 20 mm.

The supporting ChainLance always has to be free floating! Neither top nor bottom side should touch the pallet.

(Exception: Pallets from 2,0 m width, see page 37)

Example:

Measured height: 26,5 cm
➔ **setting: 28,5 cm**

Set-Mode

Save height positions L1 – L5

- 1.) Move to required height by pressing ↑↓ button
present height: 10,0 cm
- 2.) Choose required memory L1 – L5
Selected height position L: 0
- 3.) Press ‘set’-button to store
Back to Main Menu: Press ‘clear’

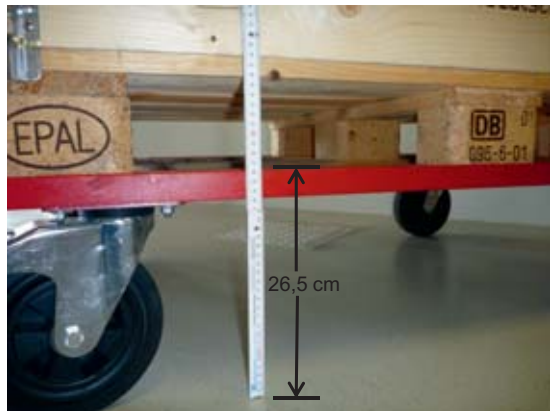

Fig. 55

To set and save the strapping height follow the three steps in the „set“-mode described in the display.

The double ChainLance has to be fully moved back into the machine before setting the pallet height. If the setting of the strapping height in the “set“-mode is activated by one of the two arrows and the ChainLance was not all the way inside the machine, the display will show a corresponding information.

6.9 Strapping



Fig. 54

1st step

Place the ErgoStrap Air parallel to the pallet according to the line laser.

For a correct distance, the laser line should run right below the lower edge of the pallet.

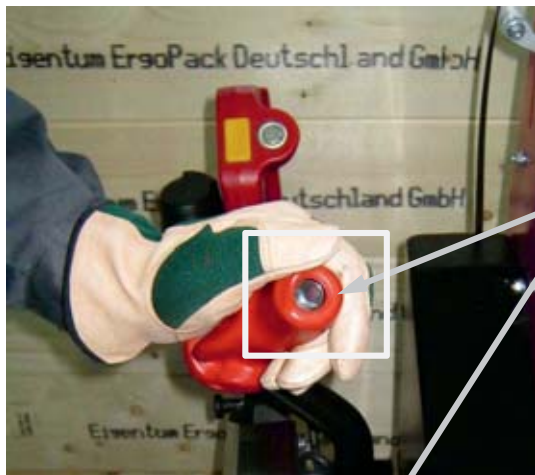

Fig. 55

2nd step

Press the button of the left handle to move down the guiding wheel.



Fig. 56

The guiding wheel keeps the machine parallel to the pallet.

If a pallet needs to be strapped several times, the machine will always remain in the same parallel position as it can only be moved for- and backwards.

By pressing the button once more, the guiding wheel moves up and the machine can be manoeuvred again freely.



Fig. 57

3rd step

Move the ChainLance out by pushing the joystick to the „move out“-direction.

The ChainLance pulls the strap through under the pallet ...



Fig. 58

...and up again on the opposite side.

When working in the “manual width setting mode”, the pallet width should be set in a way that the distance between the pallet and the rising ChainLance is about 10-20 cm.



Important!

To make sure the ChainLance moves upwards properly, it is important to push the joystick continuously until the ChainLance appears on the other side and falls towards you.



Fig. 59

Catch the ChainLance at the front edge as shown. Do not let it drop onto the package.

As soon as you have caught the ChainLance, let go of the joystick so it moves back to the middle position and the ChainLance stops moving out further.

4th step

Hold the strap with the left hand by the head piece as shown ...



Fig. 60s



Fig. 60b

...and move the ChainLance completely backwards by pushing the joystick in the „move in“ direction.



Fig. 61



Important!

Always keep the strap under a slight tension when moving back the ChainLance. This avoids the strap forming a loop at the backside of the ChainLance which could jam in the reversing unit and lead to malfunctions.

5th step

The strap lifter rises automatically after the reversing sledge has moved back into the machine.

Now relax the strap in your left hand – otherwise the strap lifter will not be able to rise.

The strap lifter will lift the strap to working height so you can reach it without bending.



Fig. 62



Important!

The strap lifter always lifts the strap up to the same height of about 70 cm, relating to the floor where the machine and the operator are positioned and independent of the set strapping height. Thereby, the operator can always seize the strap at the same convenient height.

While the strap lifter is rising, you have to hold the strap loosely in your hand.

For safety reasons, the machine will switch off automatically if you keep the strap under tension in your hand while the strap lifter rises.

The strap lifter will rise again each time you push the joystick in the “move in” direction.

If necessary you can pull out additional strap from the machine.
Do not pull directly at the strap lifter ...



Fig. 63



Fig. 64

...but about 10 cm below it.
Hold the strap with the whole hand
and pull it out of the machine.
Simultaneously, you have to relax
the strap in your other hand!

6.10 Tensioning and sealing

1st step

Overlap the straps so that the end of the strap is on the bottom.



Fig. 65

2nd step

Then hold both straps with the **right hand** as shown.

The end of the strap should be in your hand and should not protrude it.



Fig. 66

3rd step

Push the sealing tool towards the pallet with the left hand and tilt it forward at the same time so that the sealing head is positioned vertically.



Pull the rocker lever to open the clamp of the sealing head.



Fig. 67

Feed the strap with your right hand from top to bottom through the slot in the sealing head.

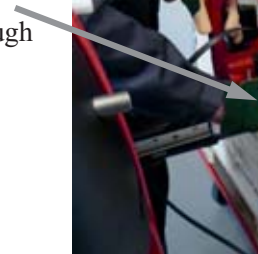

Now release the rocker lever.



Fig. 68



4th step

The tensioning and welding of the strap can be carried out in different ways, depending on the selected mode (manual or automatic).

See page 28, „setting mode of operation at sealing head“.

4.1 Manual tensioning and welding

Press the yellow tensioning button (left side, rectangular button).

The sealing unit switches off automatically once the pre-set tension force is reached (see chapter 6.4) or if the tension button is released.

After that press the silver welding button (right side, round button)

4.2 Automatic tensioning and welding

If the sealing head is in automatic mode, the welding process is activated automatically as soon as the pre-set tension force is reached.

Re-tensioning is not possible anymore now.

After the welding process is finished, a Countdown 3-2-1 with an acoustic final signal will start on the segment display. Open the rocker lever after the signal, as only then the welding has cooled down enough.

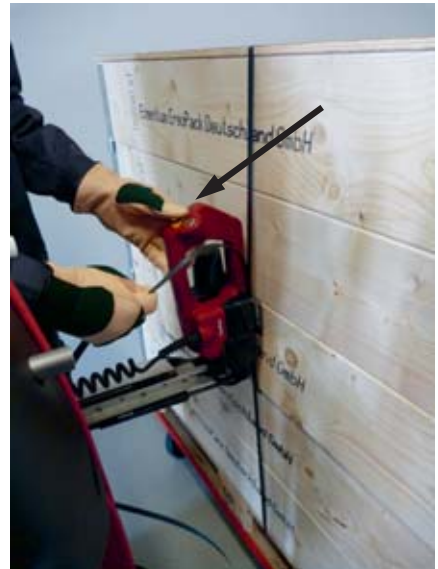

Fig. 70



Fig. 71

5th step

As soon as the countdown and the acoustic signal are finished, pull the rocker lever towards the handle.

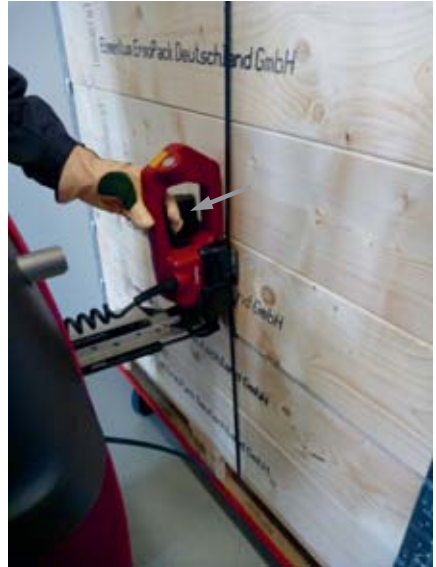

Fig. 72

6th step

Keep the rocker lever in its pulled back position and move the sealing head slightly to the left.

Important: Only if the rocker lever is fully pulled back the slot is completely open!



Important!

We recommend to clean the sealing head regularly (daily) if there is a lot of waste. Especially the tension wheel and the tooth plate should be checked for damage and kept clean.

See points 7.2 and 7.3, pages 56 and 57.

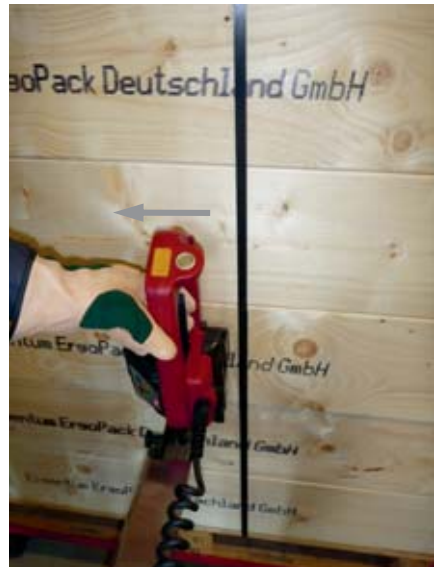

Fig. 73

6.11 Sealing control

The sealing has to be controlled regularly. The welding time must be checked in accordance with point 6.12 and adapted as necessary to avoid bad sealings.

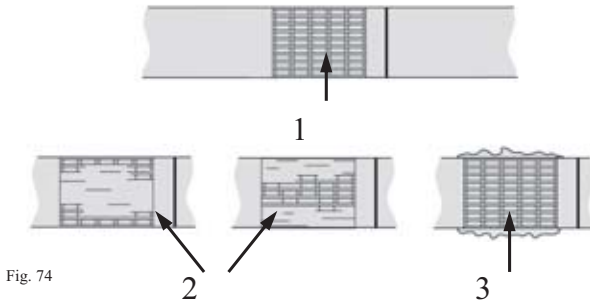

Fig. 74

1 Good sealing: the whole sealed surface has been cleanly welded without any extra material being squeezed out to the side.

2 Bad sealing: the surface has been unevenly welded, the selected welding time is too short.

3 Bad sealing: additional material is squeezed out to the side, the selected welding time is too long.



A strap with a bad sealing cannot secure the load and can lead to injuries.

Never transport or move packaged goods with a friction weld sealing which was not carried out properly.

6.12 Setting the welding time

- Press button „function“ (1).
- Press button „Welding time“ (2) several times until the flashing digital display (3) indicates the required welding time (wait for 2 seconds until the setting is saved).

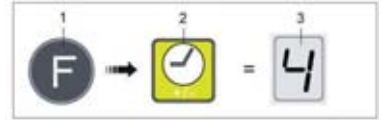

Fig. 75

1 = minimum welding time
7 = maximum welding time



If the necessary welding time is between 6 or 7 to reach a good sealing in accordance with point 6.11, there may be a fault with the tool or a worn component in the welding mechanism.

Usually, both tooth plates of the welding mechanism have to be replaced very soon.

7. Servicing and repair

Your ErgoStrap Air is made out of galvanized steel, powder coated steel, stainless steel and ultra wear-resistant plastics and is basically maintenance free.

Clean the outside of the ErgoStrap Air with a damp cloth if it is extremely dirty.



For all servicing and repair work the battery has to be unplugged and the emergency stop has to be pressed.

7.1 Cleaning the guiding ChainLance

Clean the guiding ChainLance with acetone or cleaning solvent if it has become greasy or oily. The support ChainLance does not need any cleaning.



Do not put and leave the ChainLance in a cleaning solvent.

For better protection against dirt, you may spray the guiding ChainLance with a common silicone spray.



Never use grease, oil or similar lubricants.

7.2 Cleaning/replacing the tension wheel of the sealing head

Removal

- Switch off machine and unplug the battery
- Remove four cylindrical screws (4) and remove rear strap stop (5) and cover (3)
- Remove tension wheel (1) carefully. Remove ball bearing (2) from tension wheel.
- Clean the tension wheel with compressed air (wear goggles).
- If the tension wheel teeth are covered with heavy dirt, they must be carefully cleaned with the wire brush supplied with delivery.
- Check tension wheel for worn teeth. If several teeth are broken, replace tension wheel (Respect the correct rotating direction, see arrow).

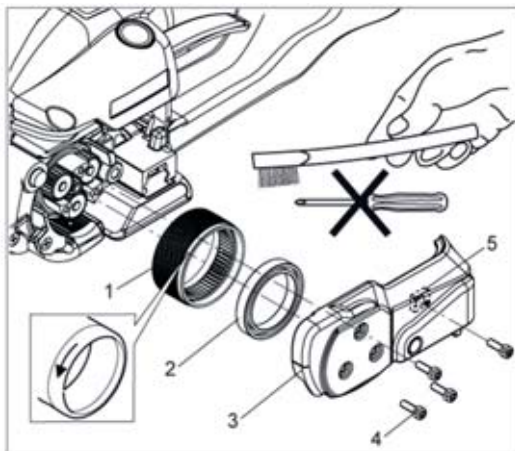

Fig. 76

The tension wheel must not be cleaned while it is rotating. Risk of breaking teeth!

Installation

- Install the parts in reverse order.
- Grease interior gear teeth of tension wheel slightly with Klüber grease GBU Y 131 (Microlube)



Important !

The tension wheel is extremely sensitive when it comes into contact with hard, especially metallic objects. Hard objects, such as screwdrivers or similar, must absolutely not be used for cleaning.

The tension wheel must not be cleaned while it is rotating.

7.3 Cleaning/replacing the tooth plate of the sealing head

Removal

- Unplug battery
- Remove pan head screw (1). Lift the rocker lever towards the handle and remove tooth plate (2).
- Clean tooth plate with compressed air (wear goggles)
- If the teeth of the tooth plate are covered with dirt, carefully clean them with the wire brush supplied or a scribe.
- Check tooth plate for worn teeth; replace tooth plate if necessary.

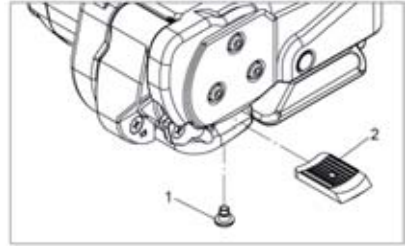

Fig. 77

Installation

- Install the parts in reverse order.
- Secure pan head screw (1) with Loctite 222.
- **The tooth plate (2) must move freely in the rocker!**

7.4 Replacing the knife of the sealing head

Removal

- Unplug battery
- Remove four cylindrical screws (2) and remove rear strap stop (3) and cover (1).
- Release pan head screw (4), remove knife (6) with flanged bushing (5) and replace both.

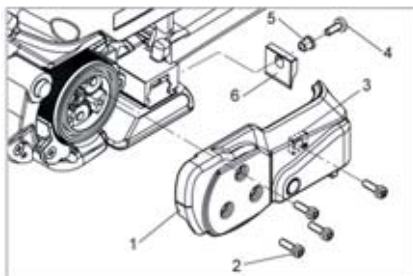

Fig. 78

Installation

- Install the parts in reverse order.
- Before installing the knife, check that the compressing spring above the knife is in place.
- Secure pan head screw (4) with Loctite 222.

7.5 Cleaning the ultrasonic sensors

If the pallet width is not recognized correctly anymore while the automatic pallet width mode is used, possibly one or both ultrasonic sensors are dirty or covered by an object (e.g. piece of wood, cardboard etc.)

Remove the object and/or the dirt.

For cleaning, just wipe with your finger over the round, white radiation points located at the front end of the sensors.

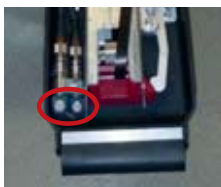

Fig. 79



Fig. 80

8. Save Moving and Parking

Moving the machine

The machine can be moved with the two ergonomically optimized handles. Before moving the machine, the brakes at both guide rolls have to be released.

Parking the machine

After the machine was parked, the brakes at the two guide rolls of the machine have to be locked in order to avoid any accidental movement.

Furthermore, the ChainLance has to be completely moved in, the key at the control unit turned left and removed and kept safely from access of unauthorized persons.

9. Spare parts lists

You will find spare parts lists and exploded drawings as well as the wiring plan on our website www.ergopack.de under “downloads“ as PDF file.

Please pay attention to type and serial number of your machine for the selection of the correct spare parts list.

Please always state the number of the article when ordering spare parts (not the position number of the part on the exploded drawing).

